

COLOSSUS[®]

Excellence inside

Multi-String MPPT Charging Control Booster
Constant Current All-In-One Machine

24160 24200

INSTRUCTION MANUAL

| Product Model | Application Scenario |
|---------------|---|
| 24160-M-2.4G | : M Multi-String MPPT Charging Control Booster Constant Current All-in-one Machine |
| 24200-M-2.4G | |
| 24160-G | : G Multi-string MPPT with induction function charging control booster constant current all-in-one machine (External induction module) |
| 24200-G | |
| 24160-I | : I Multi-string MPPT with IOT function charging control booster constant current all-in-one machine (External communication module) |
| 24200-I | |
| 24160-AC-2.4G | : AC Multi-string MPPT with AD/DC hybrid complementary function charging control booster constant current all-in-one zmachine (External power module) |

1. PRODUCT CHARACTERISTICS

1. Extremely low dormant current, more energy-saving, convenient for long-distance transportation and storage.
2. According to the real-time capacity of the battery and solar charging capacity, the power of the lighting is adjusted autonomously, which not only ensures the brightness and lighting time, but also ensures 365 day light.
3. A variety of intelligent power modes can be selected, and the load power can be automatically adjusted according to the battery power.
4. High-precision digital boost constant current control algorithm, high-efficiency and high-constant current accuracy.
5. LED short-circuit/open-circuit/ power limit protection and so on multi-protection functions.
6. Extensible sensing function.
7. Extensible IOT (Internet of Things) remote communication monitoring function.
8. All aluminum metal shell, IP67 waterproof level, can be used in a variety of harsh environments.

2. OPERATION INSTRUCTIONS

2.1 MPPT Charging Introduction

MPPT, the full name of "Maximum Power Point Tracking" (Maximum Power Point Tracking), is an advanced charging method. The MPPT controller can detect the power generation of the solar panel in real time and track the maximum voltage current value (VI), so that the system can charge the battery at the highest efficiency. Compared with the traditional PWM controller, the MPPT controller can play the maximum power of the panel, so it can provide a larger charging current, generally speaking, MPPT can improve the energy utilization rate of 15%-20% than the PWM controller.

Because the peak voltage (Vpp) of the solar panel is about 16V, and the single string lithium battery voltage is about 2.5-4.2V, if the PWM controller is used, the solar panel has been clamped at about 2.5-4.2V, and has not fully played out the maximum power. The MPPT controller can overcome this problem and adjust the input voltage and current of the panel from time to time to achieve the maximum input power.

At the same time, due to the different ambient temperature and lighting conditions, the maximum power point often changes, and the MPPT controller adjusts the parameters according to different conditions, so that the system is always near the maximum operating point.

2.2 Dormant and Wake-up:

1. Going to the dormant

- A. Press the [Exit] button of the RC1 remote control, the controller shuts down all external control devices and enters the dormant state with extremely low power consumption to avoid the lithium battery feed caused by long-term non-use;
- B. Press the [OFF] button of the RC2 remote control, the controller shuts down all external control devices and enters the dormant state with extremely low power consumption to avoid the lithium battery feed caused by long-term non-use;

Note: The dormant function is prohibited for long-term storage or transportation.

2. Wake up from the dormant



- A. After the controller is dormant, if the photovoltaic panel is connected, the controller can be awakened to charge when the charging conditions are met during the day, and the load will be automatically turned on at night.
- B. After the controller is dormant, if press the [ON] button of the RC2 remote control, you can directly wake up the controller to turn on the light even though the photovoltaic panel is not connected.

THE DORMANT AND WAKE STATE TRANSITIONS ARE AS FOLLOWS:

| Controller State Remote | Dormancy | Wake-up | Charge | Discharge | LED indicator status after dormancy |
|----------------------------|----------------------------------|----------------------|--|---|---|
| RC1 | Hold down the [Exit] button | – | – | – | Extinguish all |
| RC2 | Tap the [OFF] button | – | – | – | Extinguish all |
| Battery overdischarge | After 10 mins Automatic dormancy | – | – | – | The red indicator blinks every 1 second |
| – | – | PV charge 10 seconds | It can be charged normally during the day. | It can discharge normally after waking up at night. | – |
| RC2 | – | Tap the [ON] button | It can be charged normally during the day. | After waking up, the light will automatically turn on for 2 seconds to test whether the load is normal; It can be discharged normally at night. | – |

2.3 Status indication:

The 24160/24200 controller has three indicator lights

| LED Light | Indicative content | State | Function | Remote control system status |
|---|---|----------------|--|--------------------------------|
|  | Green indicator light Indicates charging state | Constant light | The photovoltaic panel voltage is greater than the photocontrol voltage | Start the light control |
| | | Extinguish | The photovoltaic panel voltage is less than the photocontrol voltage | Off the light control |
| | | Slow flashing | Be Charging | Be Charging |
| | | Quick flashing | Battery is fully charged | Battery is fully charged |
|  | Red indicator light Indicates battery state | Constant light | Battery is working fine | Normal operation |
| | | Extinguish | The battery is not connected or the remote shuts down | Not running or shutdown status |
| | | Slow flashing | Battery overdischarge | Overdischarge |
| | | Quick flashing | LED load short circuit | Short-Circuit |
|  | Blue indicator light Indicates load state | Constant light | The load is turned on | Discharge |
| | | Extinguish | The load is turned off | Leisure |
| | | Slow flashing | LED load percentage output | Percentage discharge |
| | | Quick flashing | LED load is disconnected | Open-circuit |
| 24160-AC | Yellow indicator light Indicates AC state | Constant light | The external power supply is turned on, and it is not connected to the AC supply | Not connected to the AC |
| | | Slow flashing | The external power supply is turned on, and connected to the AC supply. | connected to the AC |

2.4 Sensing function:

Controller is divided into two types: human infrared induction (IR) and microwave induction (WB) : Human infrared sensor is a kind of sensing product made by using the principle of pyroelectric effect, that is, a phenomenon that generates electric charge due to temperature change. The detection range of the infrared sensor probe will be affected by the difference between the temperature of the human body and the environment, and the higher the environment temperature (the closer to the human body temperature), the less sensitive the sensor.

Microwave inductive sensor is a moving object detector designed by using the principle of the Doppler effect. It detects whether the position of an object has moved by using a non-contact way, and then generates the corresponding switching operation. It has strong anti- RF interference ability, and is not affected by temperature, humidity, light, airflow, dust ,etc.

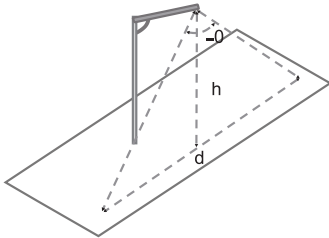

| The type of induction | θ (Angle) | H ((Light Pole Height)) | D(Induction Width) |
|-----------------------|------------------|-------------------------|--------------------|
| IR(Infrared) | 60 ° | 6 ~ 8m | 9 ~ 14m |
| WB(Microwave) | 65 ° | 6 ~ 9m | 10 ~ 16m |

2.5 IOT functions

IOT function: smart street lights IOT based on IOT technology can achieve intellectualized control of street lamp lighting, thereby improving the efficiency and quality of street lamp lighting. Main advantages:

1. On-demand lighting: realize automatic control of lighting;
2. Remote monitoring: real-time monitoring of the running status of the street lamp, and remote operation of the street lamp switch, remote adjustment of the lighting time;
3. Anomaly monitoring: It can monitor whether the street lamp is abnormal in real time, which is convenient for timely examine and repair.

2.6 AD/DC Hybrid Complementary function

AD/DC Hybrid Complementary: Solar street lights usually use solar energy systems to supply electricity, but once the battery power supply is insufficient due to weather or other reasons, the controller will switch the power supply line to AC supply.

Because of the addition of the AC, compared with the pure solar system, the lighting of the AD/DC hybrid complementary system is more stable and can not be affected by the weather, but also because the AC is needed to lay cables, so it completely loses the advantages of convenient installation of solar street lights.

The mains complementary controller cannot sleep using the remote control.

2.7 Intelligent Power

Intelligent power: When the battery supply is insufficient due to weather or other reasons, in order to ensure the lighting time, the controller starts the smart power reduction to reduce the output power in the preceding period to ensure that there is power in the later time period.

Intelligent power reduction is shown as follows:

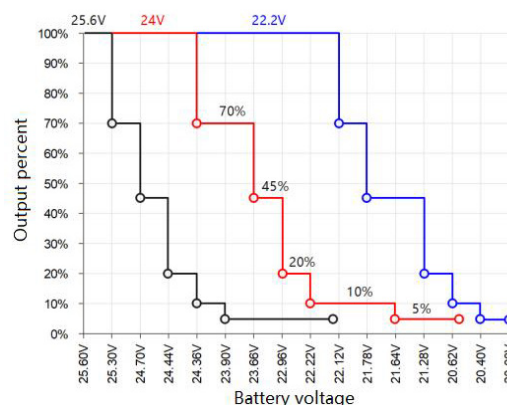

3. TECHNICAL PARAMETER

| Parameter Name | Parameter Value | | Parameter Adjustable | Default Value |
|----------------------------|---|---|----------------------|---------------|
| Model number | 24160 | 24200 | | |
| Controller type | Mppt Charging, Load Boost Constant Current | | | |
| System voltage | 22.2V/25.6V/24V | | √ | 24V |
| Static power consumption | ≤20ma | | | |
| Dormant power consumption | ≤8ma | | | |
| Load current | 0.33-5.94A | 0.33-7.26A | √ | 0.33 |
| Load voltage | 30V~48V | | | |
| Load LED string number | Vf (Lamp Bead Voltage) =3.0V: 10~16Strings Vf (Lamp Bead Voltage) =6.0V: 5~8 Strings | | | |
| Maximum load power | 80W | 120W | | |
| Load conversion efficiency | 94% | | | |
| Load current accuracy | < 3% | | | |
| Intelligent power | Automatic | | | |
| Load working period | 5 stage time control +1 stage morning light | 4 stage time control +4 stage induction | Support | |
| Time adjustment amplitude | 30Mins | | | |
| Power adjustment amplitude | 5% | | | |
| Maximum charging current | 15A | 20A | | |
| Solar input voltage | < 50V | | | |
| Solar input power | 540W | 720W | | |
| overvoltage | 25.2V/29.2V/29.2V | | | |
| Charge return voltage | 24.4V/27.6V/27.6V | | | |
| Overdischarge | 17.10V/21.7V/21.30V | | | |

| | | | |
|---------------------------------|---|-----|-----|
| voltage | | | |
| Light-controlled voltage | On: 6.5V, Off : 9.0V | √ | Mid |
| Light control delay | 5S ~ 60S | √ | 5S |
| Operating temperature | -35°C ~ +65°C | | |
| Class of protection | IP67 | | |
| Protection function | Photovoltaic Panel Reverse Connection Protection, Photovoltaic Panel Overpressure Protection, Lithium Battery Overcharge And Overdischarge Protection Lithium Battery Bms Overvoltage Detection Protection, Load Short Circuit Protection, Overtemperature Protection, Load Overcurrent Protection | | |
| Weight (g) | 530 24160-AC: 580 | 530 | |
| Controller Size (mm) | 120X99X31 | | |

4. PROTECTION FUNCTION

- **Waterproof Protection**

Waterproof rating: IP67

- **Lithium battery BMS overcharge detection protection**

When the controller detects that the BMS is overcharged, the controller immediately stops charging to prevent the high voltage of the photovoltaic end from being added to both ends of the BMS for a long time, resulting in high voltage damage to the BMS.

- **High temperature protection**

When the ambient temperature is higher than the set value, the controller stops charging and discharging to prevent the risk of damage to the lithium battery due to excessive temperature.

- **Photovoltaic input overvoltage protection**

If the input voltage of the PV panel is too high (reaches 25-30V), the controller automatically cuts off the PV input.

- **Photovoltaic input reverse protection**

When the photovoltaic array polarity is reversed, the controller will not be damaged, and will continue to work normally after correcting the wiring error.

- **Load limit power protection**

When the customer uses the LED lamp power is too large, or the regulating load current is too large, the controller will limit the load power output to less than the rated power to ensure that the controller and the LED load will not be damaged.

- **Load short-circuit protection**

When a short circuit occurs, the controller immediately cuts off the load output to prevent damage to the controller. After the load short-circuit condition is lifted, the controller will automatically restore the output within 1 minute (if it is short-circuit for a long time, it will automatically restore the output once an hour), or press the remote control test button (CU or mini2) to automatically restore the output after 10S.

- **Load open circuit protection**

When the LED load light is on normally and the load connection is suddenly disconnected, the controller is not damaged.

- **Anti-charge protection at night**

Prevent the battery from discharging through the panel at night.

5. ELECTRICAL WIRING DIAGRAM

24160 24200 Wiring Diagram:

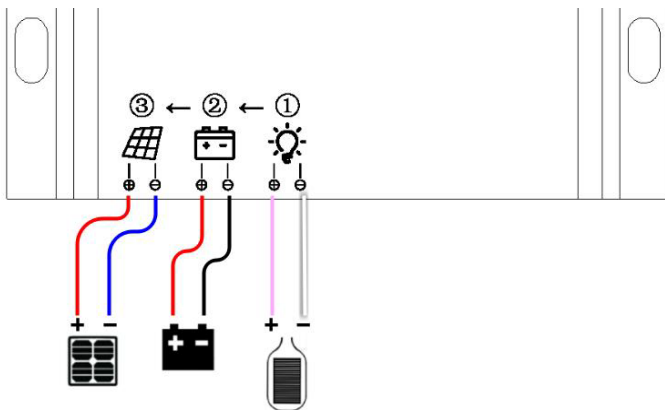

24160-AC Wiring Diagram:

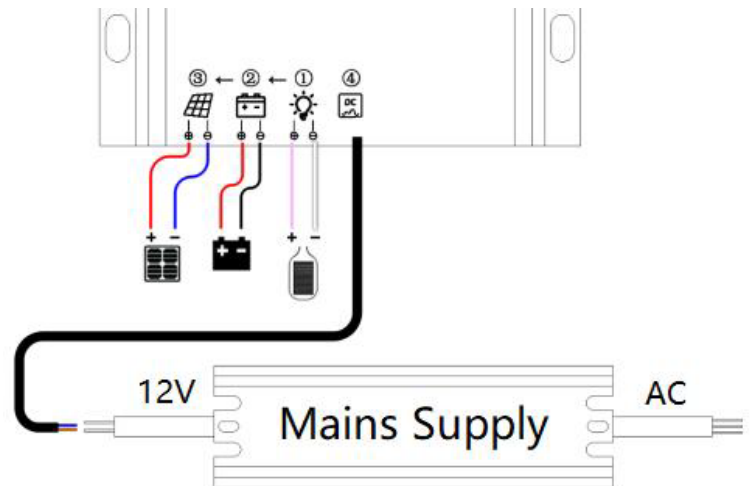

2.8 Size drawing

24160 24200 24160-AC size as follows:

Product Size: 120×99×31mm

Installation Size: 92×50

Installation Aperture: $\phi 4.0 \times 8.0$

